

# Clevis shackle ICE / VIP CCS-FASTLOX

## User Manual

This User Manual must be kept for the entire usage time and forwarded with the product.

TRANSLATION OF THE ORIGINAL USER MANUAL



ICE CCS-FASTLOX  
ICE 4 mm

ICE CCS-FASTLOX  
ICE 6-16 mm



VIP CCS-FASTLOX  
VIP 6-22 mm



**RUD Ketten**  
**Rieger & Dietz GmbH u. Co. KG**  
73432 Aalen  
Tel. +49 7361 504-1370  
slings@rud.com  
www.rud.com

RUD-Art.-Nr.: 7912399 - V03 / EN / 10.024

Clickable Clevis shackle  
**CCS-FASTLOX**



### EG-Einbauerklärung

entsprechend der EG-Maschinenrichtlinie 2006/42/EG, Anhang II B und ihren Änderungen

Hersteller: **RUD Ketten**  
**Rieger & Dietz GmbH u. Co. KG**  
Friedensinsel  
73432 Aalen

Hiermit erklären wir, dass die nachfolgend bezeichnete unvollständige Maschine den grundlegenden Anforderungen der Maschinenrichtlinie 2006/42/EG (Anhang 1) entspricht. Die nachfolgend bezeichnete unvollständige Maschine darf, in der gelieferten Ausführung erst dann in Betrieb genommen werden, wenn festgestellt wurde, dass die Maschine, in die diese unvollständige Maschine eingebaut werden soll, den Anforderungen der EG-Maschinenrichtlinie 2006/42/EG entspricht.

Produktbezeichnung: CCS-FASTLOX  
ICCS / VCCS

Folgende harmonisierten Normen wurden angewandt:  
DIN EN 1677-1 : 2009-03    DIN EN ISO 12100 : 2011-03

Folgende nationalen Normen und technische Spezifikationen wurden außerdem angewandt:  
DGUV-R 109-017 : 2020-12

Die speziellen Unterlagen zur unvollständigen Maschine nach Anhang VII Teil B wurden erstellt und werden auf begründetes Verlangen in geeigneter Form übermittelt.

Für die Zusammenstellung der Konformitätsdokumentation bevollmächtigte Person:  
Michael Betzler, RUD Ketten, 73432 Aalen

Aalen, den 23.08.2024

Hermann Kolb, Bereichsleitung MA   
Name, Funktion und Unterschrift Verantwortlicher



### EC-Mounting declaration

According to the EC-Machinery Directive 2006/42/EC, annex II B and amendments

Manufacturer: **RUD Ketten**  
**Rieger & Dietz GmbH u. Co. KG**  
Friedensinsel  
73432 Aalen  
Germany

We hereby declare that the following incomplete machines correspond to the basic requirements of the Machinery Directive 2006/42/EC (annex 1). The following incomplete machine, in the delivered machine, may only be put into operation when the machine in which the incomplete machine shall be assembled, has been tested according to the requirements of the EC-Machinery Directive 2006/42/EC.

Product name: CCS-FASTLOX  
ICCS / VCCS

The following harmonized norms were applied:  
DIN EN 1677-1 : 2009-03    DIN EN ISO 12100 : 2011-03

The following national norms and technical specifications were applied:  
DGUV-R 109-017 : 2020-12

The special documents about the incomplete machine according to annex VII part B have been created and can be handed over in a suitable form on request.

Authorized person for the configuration of the declaration documents:  
Michael Betzler, RUD Ketten, 73432 Aalen

Aalen, den 23.08.2024

Hermann Kolb, Bereichsleitung MA   
Name, function and signature of the responsible person

CONTENT

<b>1</b>	<b>Safety instructions</b>	<b>2</b>
<b>2</b>	<b>Intended use</b>	<b>2</b>
<b>3</b>	<b>Instructions for mounting and use</b>	<b>3</b>
3.1	General information .....	3
3.2	Component overview .....	3
3.2.1	CCS-FASTLOX (individual parts).....	3
3.2.2	CCS-FASTLOX (complete with pins and clamp lock).....	3
3.2.3	Clamp lock .....	3
3.3	Markings / assignment.....	4
3.4	Notes on assembly .....	4
3.5	Use of the CCS-FASTLOX .....	6
3.5.1	Important advice for use .....	6
3.5.2	Release .....	6
3.5.3	Locking.....	6
3.6	Incorrect assembly .....	8
<b>4</b>	<b>Inspection / Repair / Disposal</b>	<b>8</b>
4.1	Notes on regular checks.....	8
4.2	Test criteria for the regular visual inspection by the user.....	9
4.3	Additional test criteria for the expert / repairer.....	9
4.4	General information about repairs .....	9
4.5	Clamp lock spare parts set.....	9
4.6	Clamp lock replacement (spare parts set).....	9
4.7	Maintenance / storage .....	10
4.8	Disposal.....	10
<b>5</b>	<b>Technical data</b>	<b>11</b>



*This user manual contains information about the correct and safe use of CCS-FASTLOX.*

*Before using the CCS-FASTLOX, read the user manual carefully and in full. Ensure that you have understood all the contents. If you need further information, ask your RUD retailer or RUD application engineer.*

*Non-observation of the instructions can lead to injuries or damage and will invalidate the guarantee.*

*This user manual applies in addition to the user manual for the RUD sling chains (ICE - RUD no. 7995555, VIP - RUD no. 7101649).*

**This manual applies to the following variants of the CCS-FASTLOX (for assignment, see Pic. 4):**

- **ICE CCS-FASTLOX** - ICE clevis shackles in ICE-Pink / traffic purple (quality class 12, D1 stamping), ICE sizes 4-16 mm.
- **VIP CCS-FASTLOX** - VIP clevis shackles in VIP-Pink / Magenta (quality class 10, H1 stamping) VIP sizes 6-22 mm.

## 1 Safety instructions



### WARNING

*Incorrectly mounted or damaged CCS-FASTLOX as well as improper use can lead to injury to persons and damage to objects.*

*Check the CCS-FASTLOX carefully before each use.*

- During the lifting process, remove all body parts (fingers, hands, arms, etc.) from the danger zone, arms, etc.) out of the danger zone (danger of squeezing).
- The CCS-FASTLOX may only be used by authorised and trained persons in compliance with the DGUV Regulations 109-017 and in compliance with any valid national regulations if used outside Germany.
- RUD CCS-FASTLOX must always be used with all corresponding components:
  - **ICE CCS-FASTLOX (clevis shackles ICE)** may only be used with ICE round steel chains in the nominal thickness 4-16 mm.
  - **VIP CCS-FASTLOX (clevis shackles VIP)** may only be used with the VIP round steel chains with nominal thickness 6-22 mm.
- Lateral WLL is not permitted due to the design. (Pic. 11).
- Assembly and disassembly of the CCS-FASTLOX may only be carried out in the unloaded state.
- The shackle pin on the CCS-FASTLOX must always be the correct size, as well as completely mounted, locked, and enclosed by both ends of the clamps (see Pic. 17).
- No technical modifications must be made to the CCS-FASTLOX.
- No persons are allowed in the danger zone.
- Jerky lifting (strong impacts) must be avoided.
- Ensure a stable position of the load during lifting. Swinging must be avoided.
- Damaged or worn CCS-FASTLOX may not be used.

## 2 Intended use

- CCS-FASTLOX may only be used for the production or assembly of lifting means in connection with ICE and VIP chains as well as ICE and VIP components. They are intended as an end component for chain suspensions for connection to flanges, lugs, or lifting points.
- The described CCS-FASTLOX must only be used in locked state for lifting, lashing, or transporting loads.
- Lateral WLL is not permitted due to the design. (Pic. 11).

- CCS-FASTLOX are not suitable for constant swinging movements.
- CCS-FASTLOX may only be used for the purposes described here.

### 3 Instructions for mounting and use

#### 3.1 General information

##### • ICE temperature suitability:

##### **ICE CCS-FASTLOX (clevis shackles ICE):**

When used at temperatures exceeding 200°C, the WLL of the ICE CCS-FASTLOX must be reduced as follows:

- -60°C to 200°C no reduction
- 200°C to 250°C minus 10 %
- 250°C to 300°C minus 40 %
- Temperatures over 300°C are not permissible!

##### • VIP temperature suitability:

##### **VIP CCS-FASTLOX (clevis shackles VIP):**

When used at temperatures exceeding 200°C, the WLL of the VIP CCS-FASTLOX must be reduced as follows:

- -40°C to 200°C no reduction
- 200°C to 300°C minus 10 %
- 300°C to 380°C minus 40 %
- Temperatures over 380°C are not permissible!

- CCS-FASTLOX may not be allowed to come into contact with aggressive chemicals, acids, and their vapours.

- The WLL of the components depend on the following variables:

- Grade of the component (*Pic. 4*)
- Nominal size of the component
- Existing load case

The permissible WLL can be found in the relevant ICE and VIP user manuals (or [www.rud.de](http://www.rud.de))

#### 3.2 Component overview

##### 3.2.1 CCS-FASTLOX (individual parts)

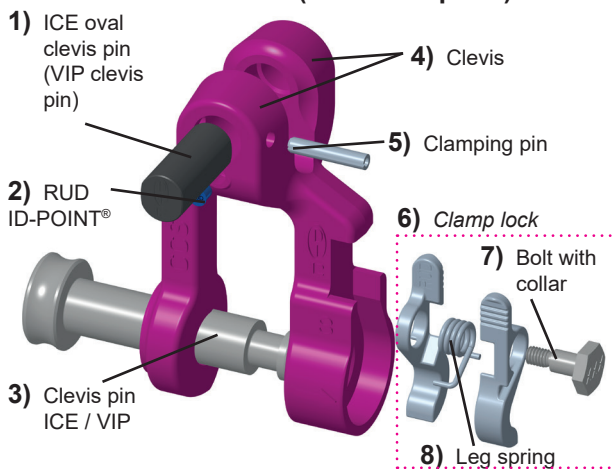

*Pic. 1: CCS-FASTLOX (individual parts)  
(for a detailed view of the clamp lock see Pic. 3)*

##### 3.2.2 CCS-FASTLOX (complete with pins and clamp lock)

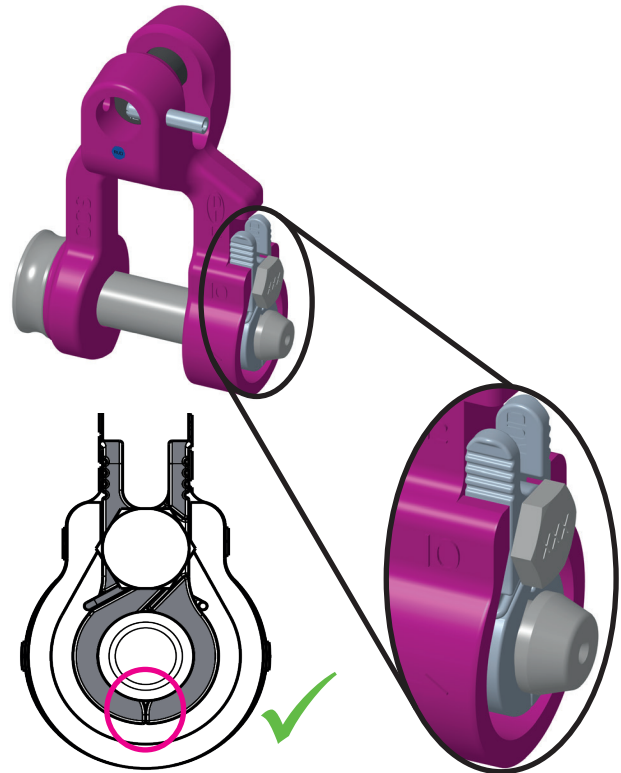

*Pic. 2: Correct assembly of the CCS-FASTLOX / clamp lock*

##### 3.2.3 Clamp lock

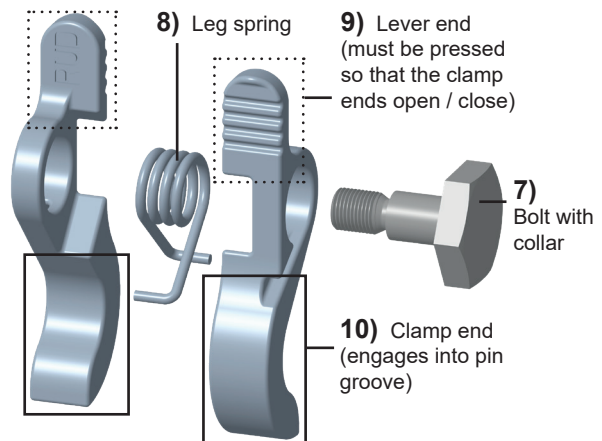

*Pic. 3: Clamp lock (individual parts)*

### 3.3 Markings / assignment

When assembling the CCS-FASTLOX, always pay attention to the correct assignment of all components (Pic. 4):

- Chains
- CCS-FASTLOX (clevis shackles)
- Clevis pins
- Shackle pin (for ICE/VIP the same with the same size)

The grades/nominal sizes of the components can be identified by the labelling/stamping on the component/shackle pin/chain or by the colour:



#### WARNING

Strictly observe the grade assignment of the components.

- For ICE CCS-FASTLOX, only mount clevis pins with D1-12 stamping.
- For VIP CCS-FASTLOX, only mount clevis pins with H1-10 stamping.

Mixing of system parts of different grades/nominal sizes is not permitted.

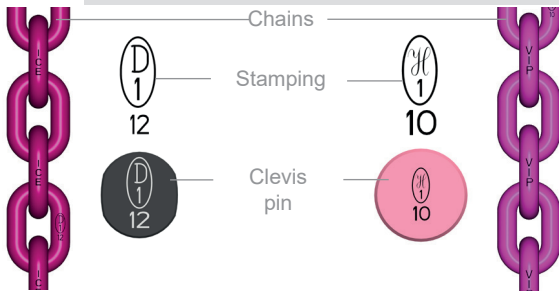

Pic. 4: Difference between ICE and VIP  
 ICE chain grade 12 | VIP chain grade 10  
 Stamping D1-12 | Stamping H1-10  
 oval bolts D1-12 | Round pins H1-10  
 marking ICE CCS-FASTLOX | marking VIP CCS-FASTLOX



#### ADVICE

Always use the appropriate size of clevis pin for the ICE or VIP CCS-FASTLOX (see marking Pic. 5).

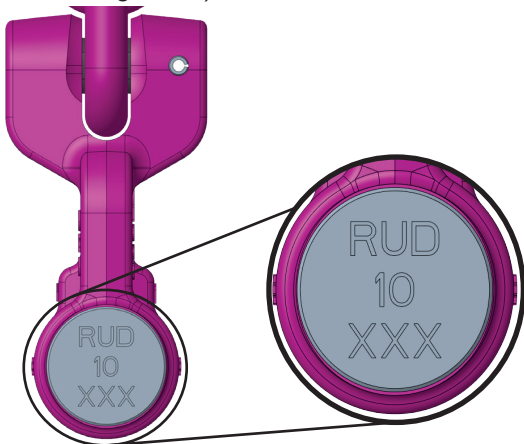

Pic. 5: Shackle pin with size information

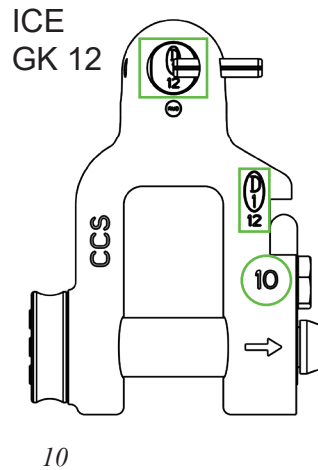

Pic. 6: Shackles with size information  
 ICE CCS-FASTLOX size 10

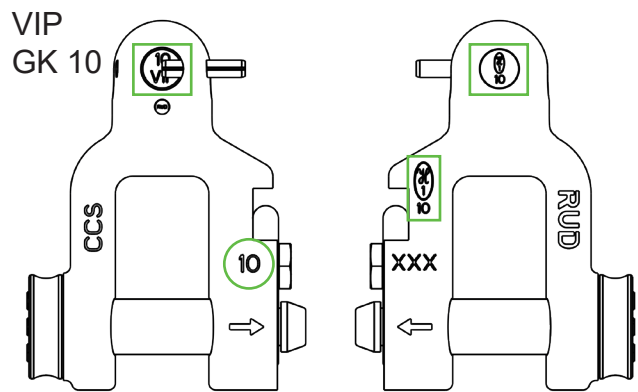

Pic. 7: Shackles with size information  
 VIP CCS-FASTLOX size 10

### 3.4 Notes on assembly



#### WARNING

When assembling the CCS-FASTLOX, always pay attention to the correct assignment of all sizes, components, and grades.

The following always applies:

- Mount the clamping pin to secure the clevis pin in the clevis in such a way that the slot of the clamping pin shows clearly to the front.
- RUD clevis pins (G-bolts) are not subject to any interference:
  - For ICE components, only use the oval ICE clevis pins (Pic. 4)
  - For VIP components, only use the round VIP clevis pins (Pic. 4)
- The clevis pin must be mounted in the component by means of the clamping pin and the stepped hole in such a way that it cannot become undone (Pic. 9).

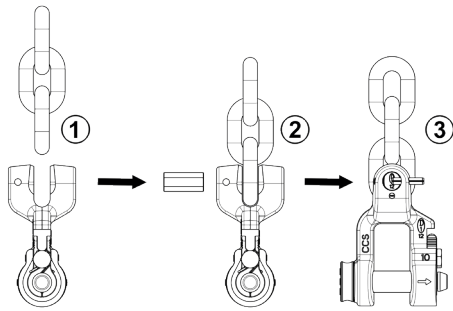

Pic. 8: Sequence for assembling the clevis pin

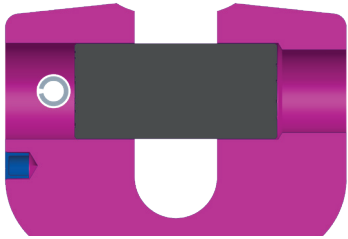

Pic. 9: Assembly of the clevis pin through clamping pin and stepped hole (left). A clevis pin of the next smaller size falls out.

- Use the clamping pin only once.
- Mount the CCS-FASTLOX on the goods to be transported in such a way that the shackle body is loaded in its longitudinal axis and no bending stress occurs (see Pic. 10 and Pic. 12).



**ADVICE**

According to EN 13889, an inclination angle  $\beta$  greater than  $7^\circ$  is not permissible.



Pic. 10: Permissible WLL in longitudinal axis

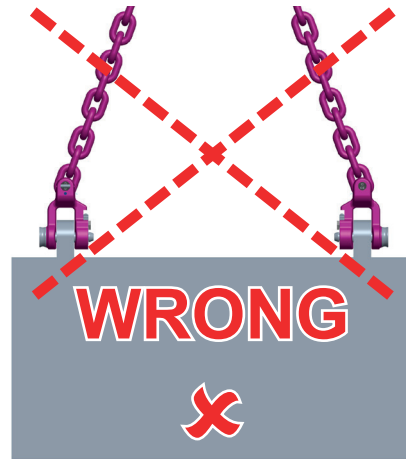

Pic. 11: Incorrect transverse load

- To avoid a one-sided WLL on the shackle, spacer washers are permitted on both sides of the clevis pin (see Pic. 12).

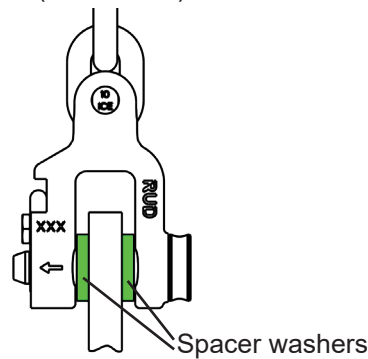

Pic. 12: CCS-FASTLOX with spacers

- Alternatively, a shackle with a smaller inside width may be used. The inside width must not be reduced by welded-in washers, spacers, or by bending the legs, as this has a negative effect on the properties of the shackle.
- Always use a stable and mounted load suspension (compare Pic. 10). The “looping” of the lifting means is not permitted.

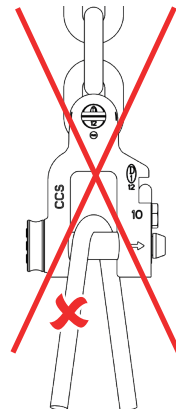

Pic. 13: Impermissible “looping”

- Only use original RUD spare parts.
- Then check that everything has been mounted correctly (see Section 4 Inspection / Repair / Disposal).



### 3.5 Use of the CCS-FASTLOX

#### 3.5.1 Important advice for use



##### WARNING

*Incorrectly mounted or damaged CCS-FASTLOX and improper use can lead to injuries and damage to people and objects.  
Check the CCS-FASTLOX carefully before every use.*



##### WARNING

*Body parts (fingers, hands, arms etc.) located within the CCS-FASTLOX can be crushed when attaching and lifting.  
When attaching / lifting components, remove appendages from the CCS-FASTLOX's area of application.*

- Regularly, before each commissioning (e.g. by the rigger), inspect the CCS-FASTLOX (strong corrosion, notches, cracks in supporting parts, deformation). See section 4 *Inspection / Repair / Disposal*).
- RUD components are designed according to DIN EN 818 and DIN EN 1677 for a dynamic WLL of 20,000 load cycles.
  - Please note that during one lifting process there might be several stress cycles.
  - Please not that due to the high dynamic load with high numbers of stress cycles there is the risk of damage to the product.
  - The DGUV recommends: At high dynamic WLL with high stress cycles (permanent operation), the working load must be reduced according to the engine group 1Bm (M3 according to DIN EN 818-7). Use lifting means with a higher WLL.
- Before WLL, ensure that:
  - The clevis pin including the clamping sleeve are correctly fitted to the CCS-FASTLOX.
  - the lock is fully closed.
  - The clevis pin is fully enclosed by the clamp lock (see *Pic. 17*).
- Avoid impacting or jolting WLL.
- If possible, leave the immediate danger zone.
- Always supervise your suspended loads.
- Observe the operating instructions for RUD sling chains for all the lifting means.

#### 3.5.2 Release



##### WARNING

*Pay attention that release of the CCS-FASTLOX may only take place in an unloaded state.*

**To release, proceed as follows:**

- 1 Simultaneously press both lever ends (1) together at the top on the clamp lock (*Pic. 14*). Both clamp ends (2) open.
- 2 Remove the clevis pins.



##### ADVICE

*If only one lever end (*Pic. 3*) (1) is actuated, the shackle pin still remains locked by one end of the clamp and cannot be removed.*

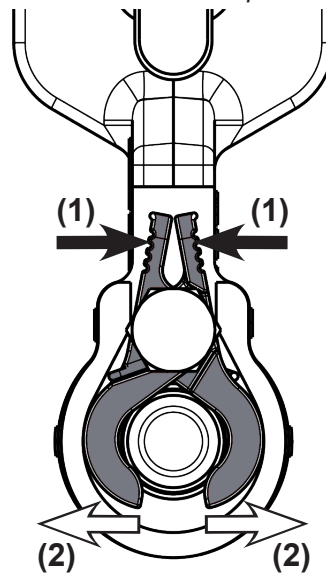

*Pic. 14: Opening mechanism*

#### 3.5.3 Locking



##### WARNING

*Make sure that the locking of the CCS-FASTLOX only takes place in the unloaded state.*



##### WARNING

*Make sure that the shackle pin is always completely mounted and engaged up to the end to the end position. This also applies if no load is attached to the chain sling.  
If not mounted correctly, the shackle pin or the load may injure persons or damage objects or get caught on edges.*

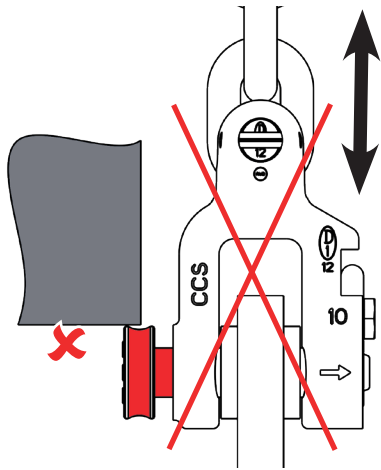

Pic. 15: Shackle pin not fully mounted

**To lock, proceed as follows:**

- 1 When locking, push the shackle pin forcefully in the direction of the arrow until it comes to rest through the openings on the CCS-FASTLOX.

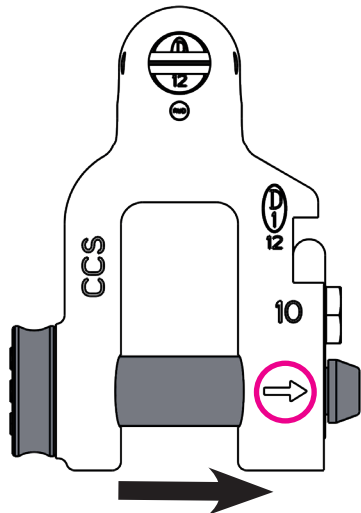

Pic. 16: Assembly direction of the shackle pin

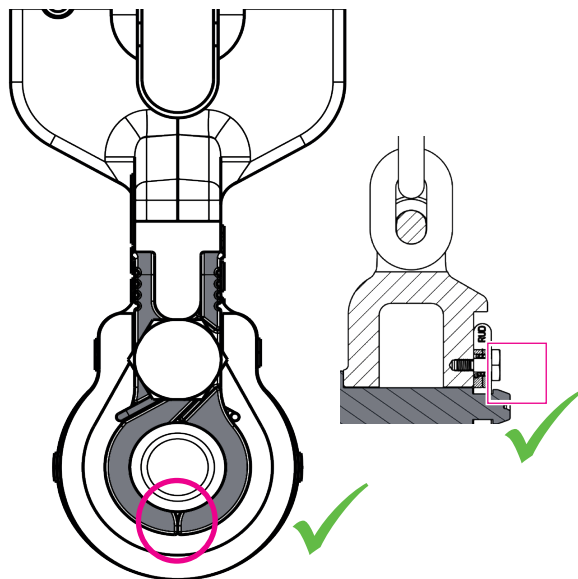

Pic. 17: Shackle pin completely encased



**IMPORTANT ADVICE**

- The shackle pin can only be mounted in the direction of the arrow (on the component) (Pic. 16)
- When correctly mounted, both ends of the pliers open and automatically engage into the groove on the shackle pin.
- Engagement is audible as well as visible.
- Both ends of the pliers must encase the shackle pin completely and touch each other at the bottom (Pic. 17).
- The shackle pin must be 360° rotatable and can no longer be removed from the shackle without operating both levers.

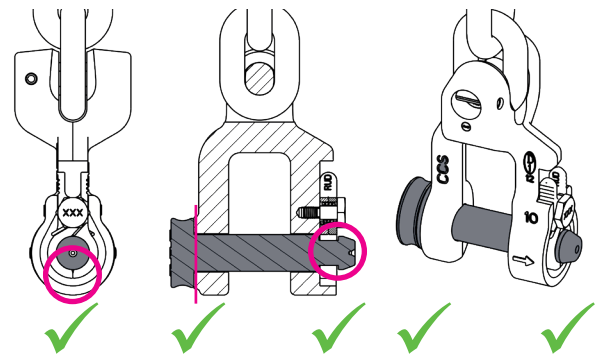

Clevis pin fully enclosed mounted flush and engaged in the groove

Pic. 18: Correct assembly

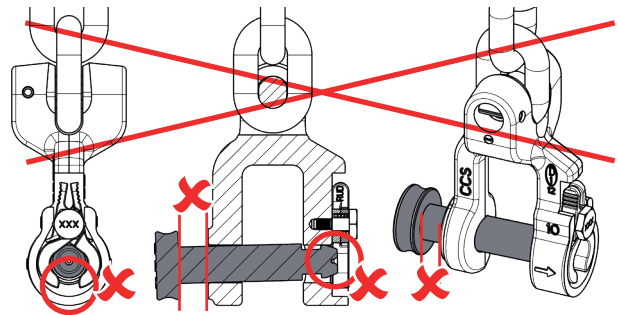

Pic. 19: Incorrect assembly (not flush or not fully mounted)

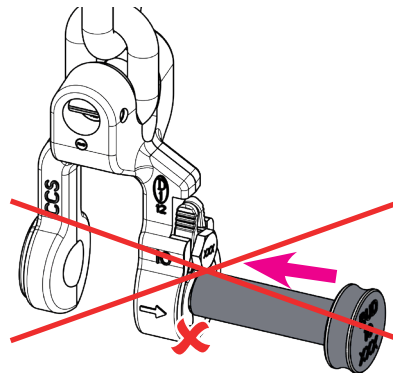

Pic. 20: Incorrect assembly (wrong assembly direction of the shackle pin)

### 3.6 Incorrect assembly

The following uses of the CCS-FASTLOX are not permitted and must be urgently avoided!



#### WARNING

*Incorrectly mounted or damaged CCS-FASTLOX and improper use can lead to injuries and damage to people and objects. Check the CCS-FASTLOX carefully before every use.*

#### Incorrect assembly:

- Clevis pin loaded on one side / inclined position of the spacer washer.

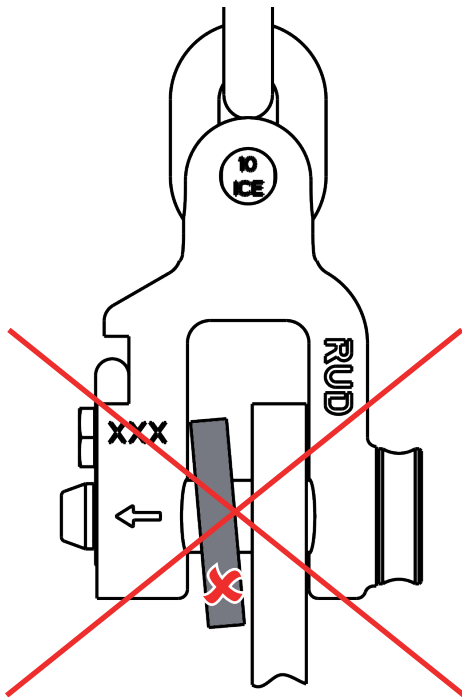

*Pic. 21: Prohibited inclined position of the spacer washer*

- The leg spring is not in the side groove of the clamp lock (compare *Pic. 25*).
- The clamp lock is not completely closed due to an object in the way (compare *Pic. 22 A and B*).

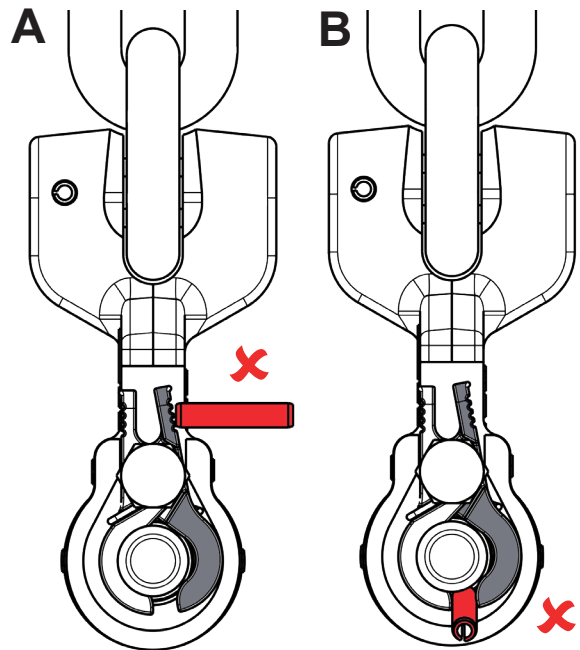

*Pic. 22: Clamp lock not closed on both sides*

- Wrong mounting direction of the clevis pin (opposite to the arrow marking on the shackle bracket, clevis pin does not engage). For correct assembly direction of the shackle pin see *Pic. 16*.
- Assembly of a clevis pin that is too large: Shackle pin cannot be mounted or cannot be fully inserted into the shackle. Observe the correct assignment (see 3.3 *Markings / assignment*).
- Assembly of a shackle pin that is too small: Shackle pin is loose and has no retention in the shackle lock. Observe the correct allocation here (see 3.3 *Markings / assignment*).

## 4 Inspection / Repair / Disposal

### 4.1 Notes on regular checks

The operator must determine and specify the nature and scope of the required tests as well as the periods of repeating tests by means of a risk assessment (see sections 4.2 and 4.3).

The continuous suitability of the CCS-FASTLOX must be checked at least once per year by an expert.

Depending on the application conditions, e.g. when used frequently or if there is a higher level of wear occurrence or corrosion, it may be necessary to carry out inspections at intervals of less than a year. This inspection is also absolutely necessary after damage and special incidents.

The inspection cycles must be specified by the operator.



#### 4.2 Test criteria for the regular visual inspection by the user

- Completeness of the CCS-FASTLOX.
- Complete, legible size information and available manufacturer symbol.
- Correct assignment of component / shackle bow and shackle pin (for grades and size assignment, see marking on the clevis pin, see *Pic. 4*).
- Shackle pins must be rotatable by 360°.
- Clamping lock must be completely closed when in use (only possible if the clevis pin is correctly mounted in the direction of the arrow)
- It must only be possible to remove the shackle pin when both levers on the clamp lock are pressed.
- The respective ICE oval load pin or VIP load pin must be freely rotatable in the CCS-FASTLOX.
- the ICE or VIP chain used must be able to move freely (without kinking)
- Mechanical damage such as large notches, in particular in areas subject to tensile loads
- Damage and wear occurrence to the lock and the shackle pin.
- Check that the bolt with collar is tightened (*Pic. 1 (Pos. 7) - Pic. 3*).
- There must be no dirt or blocking objects in the recess around the clamp lock.

#### 4.3 Additional test criteria for the expert / repairer

- Changes in cross-section due to wear occurrence > 10 %, particularly at the shackle bolt and shackle eye.
- Heavy corrosion
- Additional inspections may be necessary, depending on the result of the risk assessment (e.g. check for cracks in load-bearing parts).

#### 4.4 General information about repairs

- Repairs may only be carried out by an expert at RUD or by a specialist company authorised by RUD who have the required skills and expertise.
- Only use original RUD spare parts and enter the repairs carried out in the chain index card (of the complete lifting means) or the AYE-D.NET system.

#### 4.5 Clamp lock spare parts set

Each spare part set includes the following components (compare *Pic. 3*):

- 2x levers
- 1x leg spring
- 1x bolt with collar

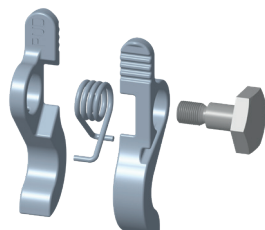

Nominal thickness	Designation	Art. no.
4 / 6	Spare part set for ICE-/VIP shackles size 4 and size 6	7912611
8	Spare part set for ICE-/VIP shackles size 8	7912612
10	Spare part set for ICE-/VIP shackles size 10	7912613
13	Spare part set for ICE-/VIP shackles size 13	7912614
16	Spare part set for ICE-/VIP shackles size 16	7912615
20	Spare part set for ICE-/VIP shackles size 20	7912616
22	Spare part set for ICE-/VIP shackles size 22	7912617

Table 1: Clamp lock spare parts set

#### 4.6 Clamp lock replacement (spare parts set)



##### WARNING

Pay attention that replacement of the clamp lock spare parts set may only take place in an unloaded state.

- 1 Remove the shackle bolt.
- 2 Release and remove the bolt with collar (compare *Pic. 3 Position 7*).

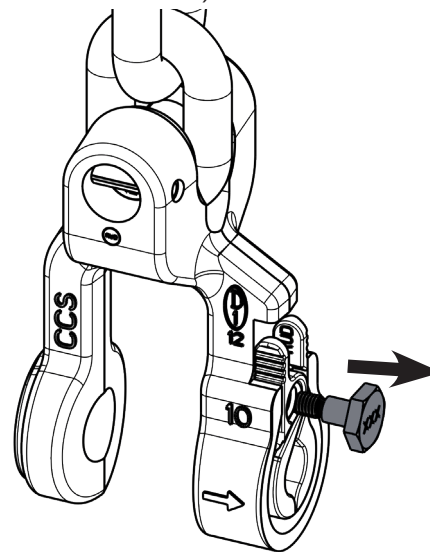

*Pic. 23: Release the bolt with collar*

- 3 Additionally remove the "old" clamp lock (2x levers, 1x leg spring).
- 4 Clean the internal thread of the CCS-FASTLOX. The internal thread must be free of grease and adhesive residues.
- 5 Mount the two levers as well as the leg spring as one unit (clamp lock). The leg spring must be fitted from the centre through both holes in the levers and inserted into the groove on each side. For the assembly sequence, see *Pic. 24*.



**NOTE**

Make sure that the correct spare part set is fitted to the clevis shackle (compare Table 1).  
Only use RUD spare parts.

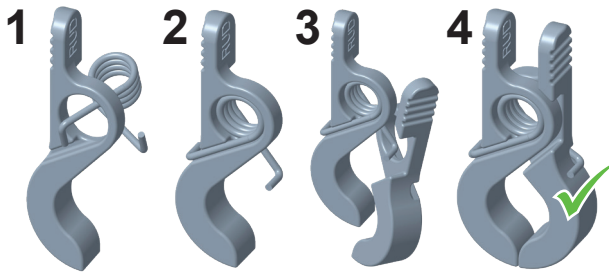

Pic. 24: Assembly sequence of leg spring

6 Make sure that the leg spring is properly inserted in the side groove.

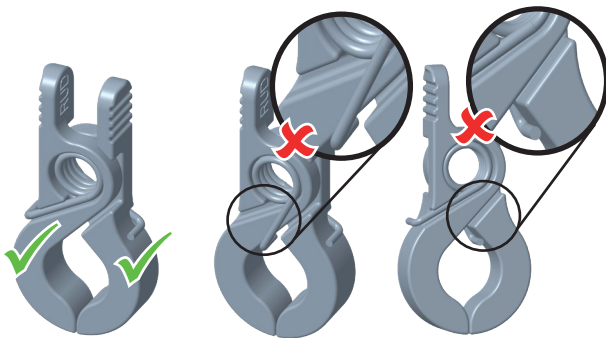

Pic. 25: Spring assembly

7 Insert the new collar bolt through the hole in the pre-assembled clamp lock as shown.

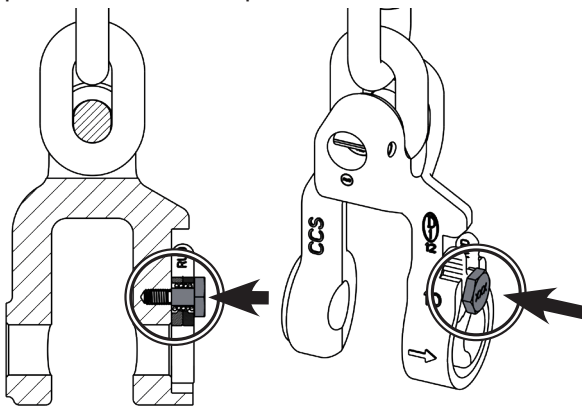

Pic. 26: Assembly of bolt with collar

8 Apply LOCTITE 603 to the external thread of the collar bolt.

9 Tighten the bolt with a torque wrench. For the torque moment, see Table 2.

Nominal thickness	Spanner size SW [mm]	Torque moment [Nm]
4 / 6	10	3
8	10	3
10	13	4
13	17	4
16	19	5
20	24	10
22	27	13

Table 2: Torque and spanner size

10 Check the function of the lock: Press the ends of the levers together. After release, both halves of the clamps must close automatically and completely.

11 Mount the clevis pins as shown in Pic. 16. The lock must engage in the end position. Both ends of the clamps must completely enclose the clevis pin and touch each other at the bottom. The clevis pin must be 360° rotatable.

**4.7 Maintenance / storage**

Always store the CCS-FASTLOX in a dry, clean, and secured position.

Care and correct storage of the lifting means maintains its quality and functionality.

**4.8 Disposal**

Dispose of the discarded components / accessories or packaging in line with local regulations.

## 5 Technical data

	Nominal thickness	WLL [kg]	T [mm]	A [mm]	B [mm]	C [mm]	D [mm]	E [mm]	F [mm]	G [mm]	Weight [kg]	Art. no.
ICE CCS-FASTLOX	4	800	41	14	8	23	10	30	51.5	24	0.17	7912242
	6	1800	36	17	8	23	10	21	51.5	32	0.184	7912243
	8	3000	50	21	10	27	12	32	64	39	0.348	7912244
	10	5000	60	27	13	36.5	16	35.5	80	51	0.764	7912245
	13	8000	77	33	17	45.5	20	41.5	103	68	1.587	7912246
	16	12500	95	38	21	55	24	49	123.5	80	2.954	7912247
VIP CCS-FASTLOX	6	1500	36	17	8	23	10	21	51.5	32	0.185	7912219
	8	2500	50	21	10	27	12	32	64	39	0.351	7912220
	10	4000	60	27	13	36.5	16	35.5	80	51	0.766	7912221
	13	6700	77	33	17	45.5	20	41.5	103	68	1.599	7912222
	16	10000	95	38	21	55	24	49	123.5	80	2.963	7912223
	20	16000	108	47	27	65	30	57	153.5	90	5.019	7912224
	22	20000	130	53	30	76	36	72.5	172	97	7.298	7912225

Table 3: Dimensions

Subject to technical modifications

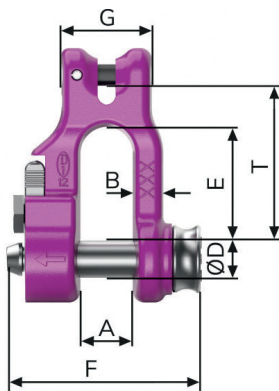

Pic. 27: ICE CCS-FASTLOX 4 mm

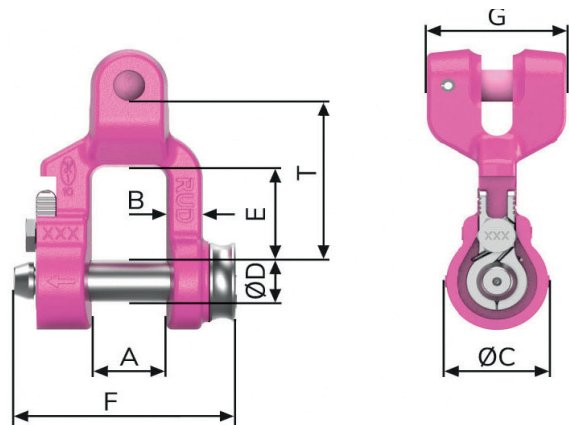

Pic. 29: VIP CCS-FASTLOX 6-22 mm

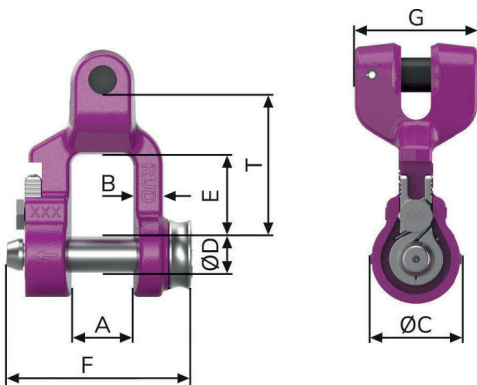

Pic. 28: ICE CCS-FASTLOX 6-16 mm