

Weld-On Lifting Point -
loadable from any side - stainless steel
> INOX-ABA <

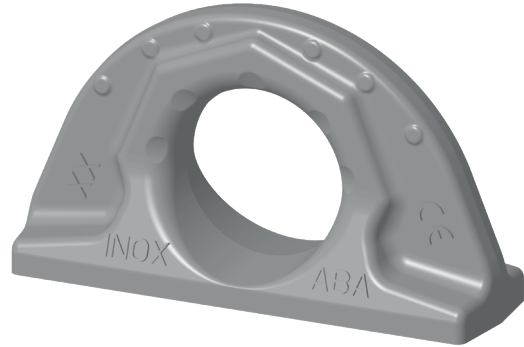

Safety instructions

This safety instruction has to be kept on file for the whole lifetime of the product and forwarded with the product.
Translation of the original safety instruction



INOX-ABA



RUD Ketten
Rieger & Dietz GmbH u. Co. KG
73428 Aalen
Tel. +49 7361 504-1370
Fax +49 7361 504-1171
slings@rud.com
www.rud.com

RUD-Art.-Nr.: 7912400 - EN / V03 / 12.022

EG-Konformitätserklärung

entsprechend der EG-Maschinenrichtlinie 2006/42/EG, Anhang II A und ihren Änderungen

Hersteller: **RUD Ketten Rieger & Dietz GmbH u. Co. KG**
Friedensinsel
73432 Aalen

Hiermit erklären wir, dass die nachfolgend bezeichnete Maschine aufgrund ihrer Konzipierung und Bauart, sowie in der von uns in Verkehr gebrachten Ausführung, den grundlegenden Sicherheits- und Gesundheitsanforderungen der EC-Maschinenrichtlinie 2006/42/EG sowie den unten aufgeführten harmonisierten und nationalen Normen sowie technischen Spezifikationen entspricht.
Bei einer nicht mit uns abgestimmten Änderung der Maschine verliert diese Erklärung ihre Gültigkeit.

Produktbezeichnung: Anschlagpunkt starr INOX-ABA

Folgende harmonisierten Normen wurden angewandt:

<u>DIN EN 1677-1 : 2009-03</u>	<u>DIN EN ISO 12100 : 2011-03</u>
_____	_____
_____	_____
_____	_____

Folgende nationalen Normen und technische Spezifikationen wurden außerdem angewandt:

<u>DGUV-R 109-017 : 2020-12</u>	_____
_____	_____
_____	_____
_____	_____

Für die Zusammenstellung der Konformitätsdokumentation bevollmächtigte Person:
Michael Betzler, RUD Ketten, 73432 Aalen

Aalen, den 25.08.2022 Hermann Kolb, Bereichsleitung MA *Hermann Kolb*

Name, Funktion und Unterschrift Verantwortlicher

EC-Declaration of conformity

According to the EC-Machinery Directive 2006/42/EC, annex II A and amendments

Manufacturer: **RUD Ketten Rieger & Dietz GmbH u. Co. KG**
Friedensinsel
73432 Aalen

We hereby declare that the equipment sold by us because of its design and construction, as mentioned below, corresponds to the appropriate, basic requirements of safety and health of the corresponding EC-Machinery Directive 2006/42/EC as well as to the below mentioned harmonized and national norms as well as technical specifications.
In case of any modification of the equipment, not being agreed upon with us, this declaration becomes invalid.

Product name: Lifting point for welding INOX

The following harmonized norms were applied:

<u>DIN EN 1677-1 : 2009-03</u>	<u>DIN EN ISO 12100 : 2011-03</u>
_____	_____
_____	_____
_____	_____

The following national norms and technical specifications were applied:

<u>DGUV-R 109-017 : 2020-12</u>	_____
_____	_____
_____	_____
_____	_____

Authorized person for the configuration of the declaration documents:
Michael Betzler, RUD Ketten, 73432 Aalen

Aalen, den 25.08.2022 Hermann Kolb, Bereichsleitung MA *Hermann Kolb*

Name, function and signature of the responsible person





Before initial usage of the RUD weld-on lifting point INOX-ABA, please read carefully the safety instructions.

Make sure that you have understood all subjected matters. Non-observance can lead to serious personal injuries and material damage and eliminates warranty.

1 Safety instructions



ATTENTION

Wrong assembled or damaged INOX-ABA as well as improper use can lead to injuries of persons and damage of objects when load drops.

Please inspect all INOX-ABA before each use.

- Remove all body parts (fingers, hands, arms, etc.) out of the hazard area (danger of crushing or squeezing) during the lifting process.
- INOX-ABA must only be used by instructed and competent persons considering DGUV-rules 109-017 and outside Germany noticing the country specific statutory regulations.
- The load capacity specified on the lifting point must not be exceeded.
- No technical alterations must be implemented on the INOX-ABA.
- No people may stay in the danger zone.
- Jerky lifting (strong impacts) should be prevented.
- Always ensure a stable position of the load when lifting. Swinging must be prevented.
- Damaged or worn INOX-ABA must never be utilised.

2 Intended use

INOX-ABA must only be used for the assembly at the load or at lifting means.

They are intended to be hinged into lifting means.

INOX-ABA can also be used as lashing points to attach lashing means.

Loading from any side is permitted.

INOX-ABA must not be hot dip galvanized.

INOX-ABA must only be used in the hereby described operation purpose.

3 Material properties

The ferrite-austenite structure of 1.4462 shows excellent corrosion resistance in acidic environments. In particular in phosphoric and organic acids, also in chlorine-containing media. The corrosion resistance is higher compared to the standard austenites (e.g. 1.4301, 1.4541, 1.4404). Due to the duplex structure of the microstructure, 1.4462 is usually superior to the austenitic steels, as it is insensitive to intergranular corrosion and particularly resistant to stress corrosion cracking, pitting and crevice corrosion.

1.4462 is resistant to seawater and media containing H₂S. RUD INOX-ABA can be used in a wide range of applications, such as in the construction industry, the chemical industry, the petroleum industry, the food industry (moderate resistance to lactic acid!), in mechanical engineering, e.g. as a FGD component, in desalination plants, OFF Shore applications and in shipbuilding.

The material 1.4462 is also suitable for applications in the nuclear technology, as far as the nuclear rules or object-related specifications allow the use.

4 Assembly- and instruction manual



HINT

The manufacturer RUD guarantees the overall conformity of the INOX-ABA only after complete and correct implementation of the assembly and welding specifications!

4.1 General information

- Capability of temperature usage:

The INOX-ABA may be used in the temperature range from -40°C to 250°C. If necessary, take into account temperature-related reductions in the load-bearing capacity of other connection components used.



HINT

After use above the maximum specified temperature, further use is no longer permitted and the lifting point must be replaced.

The quality / safety of the lifting point is then no longer guaranteed.



HINT

The material 1.4462 tends to „475° embrittlement“ and also to sigma phase embrittlement, therefore the use of this material is limited to temperatures below 350°C!

Exception: INOX-ABA can be stress-relieved one-time in an unloaded condition, together with the load (e.g. welded construction). Temperature < 580°C / 1050°F (one hour maximum).

- The reuse of cut-off ABAs is not permitted
- INOX-ABA must not be used with aggressive chemicals such as acids, alkaline solutions and their vapours.
- Please mark mounting position of INOX-ABA with a coloured contrast paint for better visibility.

4.2 Hints for the assembly

Basically essential:

- The material construction to which the lifting point will be attached should be of adequate strength to withstand forces during lifting without deformation. The weld-on material must be suitable for welding and the contact areas must be free from impurities, oil, colour, ect. The material of the lifting point for welding is: 1.4462
- The position of the lifting points must be carried out in such a way that unintended movement like turning or flipping will be avoided.
 - For single leg lifts** - the lifting point should be vertically above the centre of gravity of the load.
 - For two leg lifts** - the lifting points must be equidistant to/or above the centre of gravity of the load.
 - For three and four leg lifts** - the lifting points should be arranged symmetrical around the centre of gravity:
- Position weld-on lifting points INOX-ABA into the load force direction (compare *Abb./Pic. 5* permissible WLL at different loading directions).
- Symmetry of loading: Determine the necessary WLL of each INOX-ABA for a symmetrical or an unsymmetrical load by using the following physical calculation formula:

$$W_{LL} = \frac{G}{n \times \cos \beta}$$

W_{LL} = necessary WLL (kg) of lifting point / single strand
 G = weight of load (kg)
 n = number of load bearing strands
 β = inclination angle of single strand

Number of load bearing strands:

	symmetric	unsymmetric
two leg	2	1
three / four leg	3	1

Table 1: Load bearing strands (compare to Table 5)

- Check finally the correct assembly (see chapter 5 *Inspection / repair / disposal*).

4.3 Hints for the welding

Observe the following when preparing for welding:

- Clean the welding areas.
- Match the heat guidance during welding to the component geometry. A line energy of 1-3 kJ/mm is recommended.
- Limit interpass temperatures between 120 and 250°C.
- Avoid rapid cooling of the weld.
- For better austenite formation, it may be necessary to heat the workpiece to approx. 100°-120°C.
- The material can be welded with short-spray or impulse arc. The pulse technique is recommended.

4.4 Procedure for welding

The welding should only be carried out according to ISO 9606-1 or AWS Standards by an authorized welder.



HINT

Weld all seams in the same temperature.

Procedure:

- 1 Fasten provisionally, resp. start welding in the middle of the plate.
- 2 Before the closure weld is carried out, make sure that the bottom and all interlayers are cleaned carefully. Remove all visible flaw spots of the root and at the interlayers.
- 3 Weld the fillet weld circumferentially and without interruption at the base plate of the weld-on point.



HINT

To avoid possible crevice corrosion, please weld the lifting point circumferentially! Please observe the current DIBt technical approval Z-30.3-6, paragraph 2.1.6.2, 2.1.6.3 und 2.1.6.4.



HINT

Due to the (forged) shape of the INOX-ABA (sizes 0.8 t, 1.6 t and 2.7 t) there will be a weld-seam changeover in the marked area (see Pic. 1 A and B). This has no impact on the strength of the construction part!

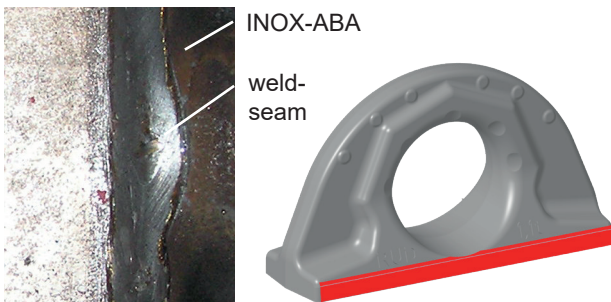

Pic. 1: A: weld-seam B: area of the weld-seam-changeover

- 4 Please check by a competent person after welding the ongoing usage of the INOX-ABA (see chapter 5 *Inspection / repair / disposal*).



HINT

By the position of the weld-seam (Fillet weld continuous) the following requirements will be observed: DIN 18800 steel constructions requires: at outdoor buildings or when strong corrosion must be expected weld seams must be carried out as continuous fillet weld seams.

4.5 User instructions

- Check frequently and before each initial operation the whole INOX-ABA in regard of linger ability as a lifting mean, regarding corrosion, wear, deformation etc. (see chapter 5 *Inspection / repair / disposal*).



ATTENTION

Wrong positioned or damaged INOX-ABA as well as improper use can lead to injuries of persons and damage at property, when load falls down.

Please check all INOX-ABA carefully before every usage.

- Please check carefully the wear indicator markings of the INOX-ABA (see Pic. 2):



No wear
Material above wear marks visible.

Use prohibited
Replacement criteria reached. Material all the way down to the wear lenses has gone

Pic. 2: Wear indicators

- Please note that the lifting mean must be free moveable within the INOX-ABA. When lifting means (sling chains) are hinged or unhinged, no pinching, shearing or joint spots must occur during the handling.
- Avoid damage of lifting means resulting from sharp edges.
- If the INOX-ABA are used exclusively for lashing, the value of the working load limit can be doubled: $LC = 2 \times WLL$.



HINT

If the INOX-ABA is/was used as a lashing point, with a force higher than the WLL, it must not be used as a lifting point afterwards.

If the INOX-ABA is/was used as a lashing point, up to the WLL only, it can still be used afterwards as a lifting point.

5 Inspection / repair / disposal

5.1 Hints for periodical inspections

The operator must determine and specify the nature and scope of the required tests as well as the periods of repeating tests by means of a risk assessment (see sections 5.2 and 5.3).

The continuing suitability of the lifting point must be checked at least 1x year by an expert.

Depending on the usage conditions, f.e. frequent usage, increased wear or corrosion, it might be necessary to check in shorter periods than one year.

The inspection has also to be carried out after accidents and special incidents.

5.2 Test criteria for the regular visual inspection by the user

- Completeness of the lifting point
- Complete, readable WLL statements as well as manufacturer sign
- Deformation at load bearing components like base body
- Mechanical damage, like strong notches, especially in areas where tensile stress occurs

5.3 Additional test criteria for the competent person / repair worker

- Reduction of cross-section due to wear > 10 % (see Pic. 2)
- Evidence of corrosion (Pitting)
- Other damage
- Further tests may be necessary, depending on the results of the risk assessment (e.g. testing for cracks on load-bearing parts / cracks or other damage to the weld).

5.4 Disposal

Dispose worn out components / attachments or packaging according to the local waste removal requirements.

6 Tables

Type	size fillet weld	length	volume
INOX-ABA 0.8 t	a = 3	177 mm	1.593 cm ³
INOX-ABA 1.6 t	a = 4	251 mm	4.016 cm ³
INOX-ABA 2.7 t	a = 6	344 mm	12.38 cm ³

Table 2: Weld seam

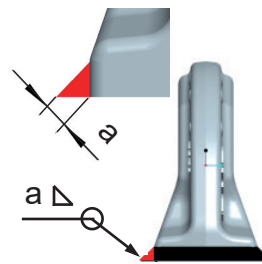

Pic. 3: Welding seam position



HINT

Heat the workpiece to approx. 100°-120°C for better austenite formation.

Welding process	Welding filler metal
MAG 135	DIN EN ISO 14343: SG 22 9 3NL material number 1.4462
WIG 141	DIN EN ISO 14343: WSG 22 9 3NL material number 1.4462
Electrode 111	DIN EN ISO 3581: E 22 9 3 L material number 1.4462
Cored wire 136, 138	DIN EN ISO 17633: T 22 9 3 L material number 1.4462

Table 3: Welding procedure and Welding filler metals



HINT

In welding procedures 111 and 136, welding consumables with basic character may have larger approval scopes.

The ABA-INOX can be welded to these base materials:	
on austenitic-ferritic steels	1.4417; 1.4462 (DIN EN ISA 10088 Teil 2 und Teil 3)
on stainless steels	1.4301; 1.4404; 1.4435; 1.4541; 1.4550; 1.4571
on general structural steels (EN 10025)	S235; S275; S355
to high-temperature structural steels	16Mo3
Additional welding instructions:	
Shielding gases	DIN EN ISO 14175: M1.2, I.1 **
Welding positions	PA, PB, PC, PF **
Weld metal untreated	Minimum values at 20°C (actual values are higher. Actual values can be taken from the approval data sheets.)
Yield strength $R_{p0,2}$	480 MPa
Ultimate tensile strength R_m	680 MPa
Elongation at fracture A_5	25 %
Notched bar impact energy A_v (ISO V at -60°C/>32J)	40 J



HINT

Observe the respective processing instructions for the welding procedures and filler materials as well as the other welding instructions.



HINT

The actual material characteristics of the material batch to be processed are always to be taken from 3.1 or 3.2 acceptance test certificates according to DIN EN 10204.

** The scope of approval of the welding filler material used can be taken from the respective valid regulations (e.g. DIBt Z-30-3.6) and the valid approvals (e.g. VDTÜV, DB).

Table 4: Welding information

Method of lift												
Number of legs	1	1	1	2	2	2	2	2	2	3 / 4	3 / 4	3 / 4
Angle of inclination	0°	90°	90°	0°	90°	90°	0-45°	>45-60°	Un-symm.	0-45°	>45-60°	Un-symm.
Factor	1	1	1	2	2	2	1.4	1	1	2.1	1.5	1
Type	For the max. total load weight >G< in metric tons											
INOX-ABA 0.8 t	3	0.8	3	6	1.6	6	1.12 (4.24)	0.8 (3)	0.8 (3)	1.7 (6.3)	1.18 (4.5)	0.8 (3)
INOX-ABA 1.6 t	5	1.6	5	10	3.2	10	2.2 (7.1)	1.6 (5)	1.6 (5)	3.4 (10.6)	2.4 (7.5)	1.6 (5)
INOX-ABA 2.7 t	7.5	2.7	7.5	15	5.4	15	3.8 (10.5)	2.7 (7.5)	2.7 (7.5)	5.7 (15.75)	4 (11.25)	2.7 (7.5)
	At a lift with one strand and two parallel strands where the inclination angles are at the max. ± 7°. the lifting methode can be assumed as a vertical lift.						When lifting with two, three or four leg lifting means, inclination angles of less than 15° shall be avoided, if possible (Risk of instability).					

Table 5: WLL-overview

> 1X



= Loading at ring plane



= Loading from the side

Example INOX-ABA 2,7 t 2-leg 0-45°:

WLL x Factor:
2.7 t x 1,4 = **3.8 t**

WLL x Factor (Bracket value):
7.5 t x 1,4 = **10.5 t**

Type	WLL [t] <small>WLL</small>	A [mm]	B [mm]	C [mm]	D [mm]	E [mm]	F [mm]	T [mm]	weight [kg/pc.]	Ref.-No.
INOX-ABA 0.8 t	0.8	22	12	70	32	12	50	38	0.2	7912396
INOX-ABA 1.6 t	1.6	30	16	100	35	16	57	41.5	0.45	7912397
INOX-ABA 2.7 t	2.7	41	23	137	50	21	80	59	1.1	7912398

Table 6: Dimensioning

Subject to technical alterations

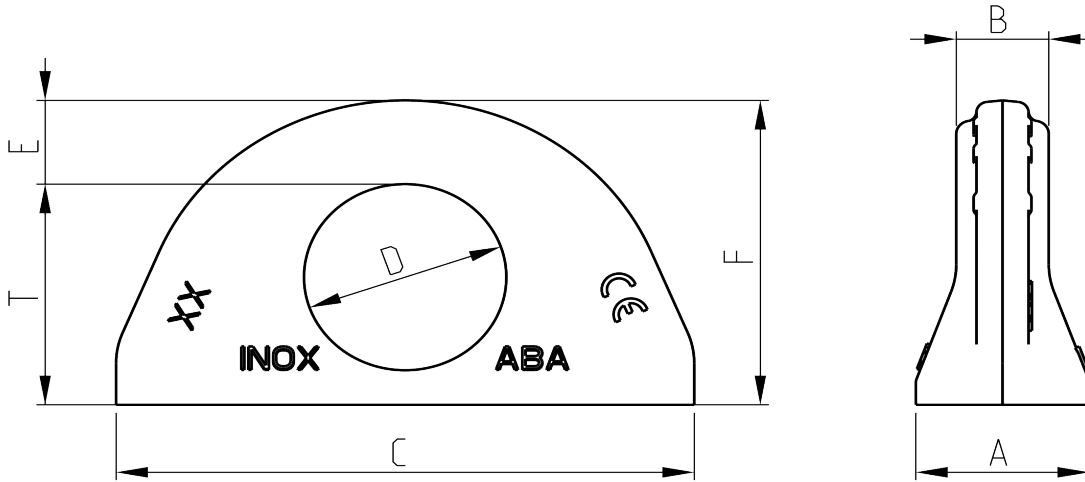

Abb./Pic. 4: Dimensioning

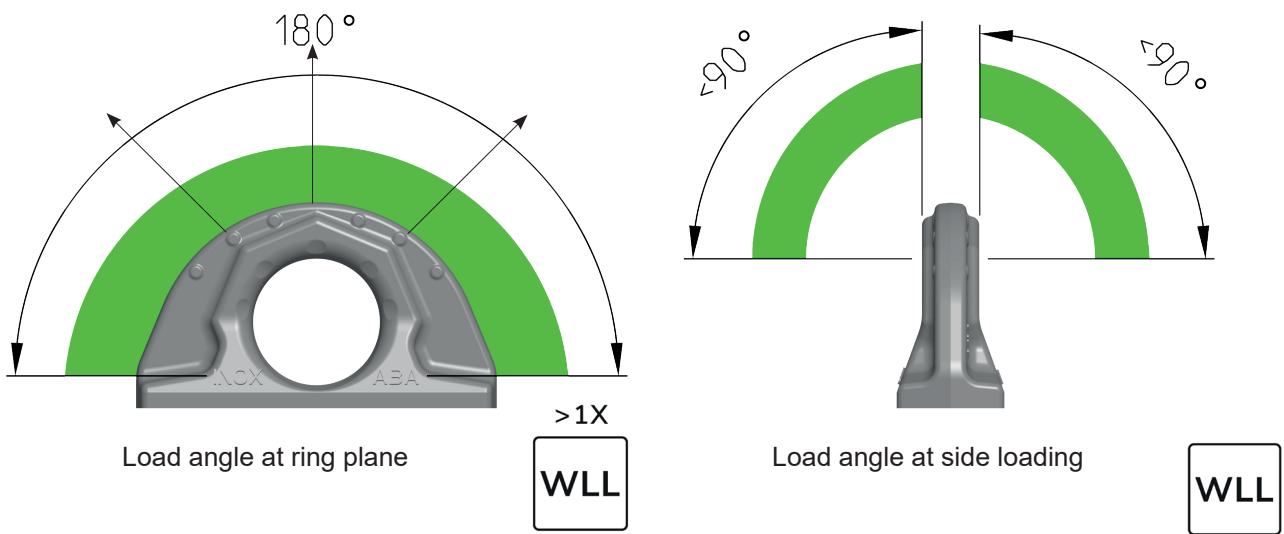

Abb./Pic. 5: Permitted loading directions